

# A Simple, But Critical Idea

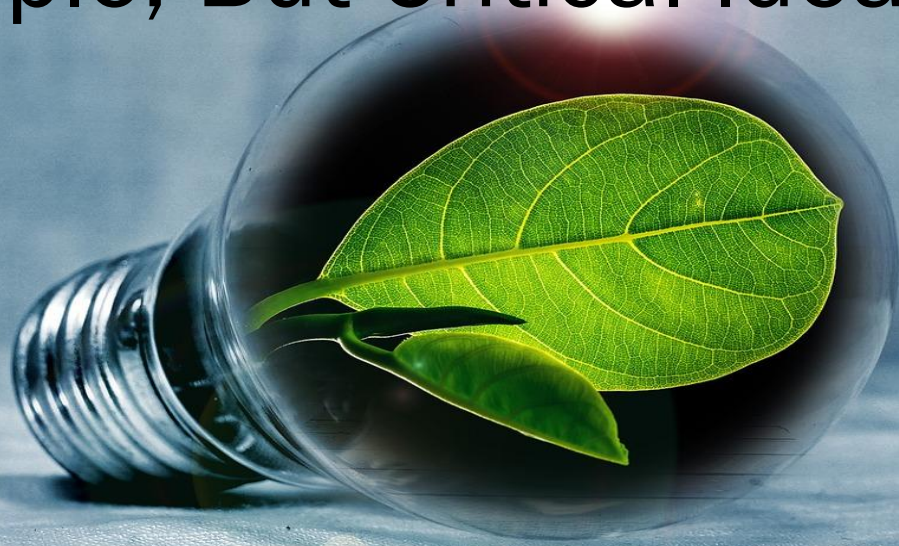

## EDGE enterprises, LLC

---

RESTORING WHAT MOTHER NATURE HAS DESTROYED IS URGENT; BUT WHY DO IT CONVENTIONALLY, ONLY TO DO IT ALL OVER AGAIN AND AGAIN AND AGAIN?

HERE IS OUR SOLUTION:

AMERICAN INGENUITY  
AMERICAN INNOVATION



*A manufacturing company  
in a factory-controlled environment*

# Discover What We Are Doing and How We Do It

---

The narrative that follows describes our building process and how it solves problems conventional building methods do not. At its conclusion, we speak to what is financially required to address:

1. How EDGE homes and commercial structures **resist natural disasters**;
2. How EDGE Enterprises can insert its intellectual and building industry expertise to solve our **nation's housing crisis**;
3. EDGE's **capital needs** – factory space, equipment to begin production, initial salaries, and computerized technology software.

Factory space has been identified, vendor relations have been established, and a Letter of Intent to build 71 homes using EDGE's CCS building method is on the table.

**Leading the Building Industry's Future with Authentic Sustainability, Proven  
Technology, Economic Disaster Prevention and Recovery, while Saving Lives, Property and  
Preserving the Environment;  
an Invitation to Invest**

From the onset of the 21st century, humanity has witnessed an extraordinary spate of disasters spawned by earthquakes, wildfires, and a variety of severe weather events. These weather events include drought, flooding, freezing, severe storms, and tropical cyclones. Since 1980, more than 400 weather and climate disasters which exceeded \$1 Billion in damage have been recorded in the U. S. alone, costing some 17,000 deaths and approximately \$3 Trillion in damages, for an average of \$64 Billion per year.

In the US during the five-year period of 2020-2024, 115 such events were responsible for 2520 deaths and \$756 Billion in damages in America alone. The year 2024 saw 27 separate billion-dollar events resulting in 568 deaths and costing more than \$180 Billion.

# U.S. 2024 Billion-Dollar Weather and Climate Disasters

Drought/Heat Wave
 Flooding
 Hail
 Severe Weather
 Tornado Outbreak
 Tropical Cyclone
 Wildfire
 Winter Storm/Cold Wave



This map denotes the approximate location for each of the 27 separate billion-dollar weather and climate disasters that impacted the United States in 2024.

Source: <https://www.ncei.noaa.gov/access/billions/>

Additionally, events of the first 3 months of 2025 are still being assessed and are expected to pass the \$1 Billion mark in damages as well:

- 1) the Los Angeles Wildfires of Eaton and Palisades may be the single most costly event to date;
- 2) Southern and Eastern U.S. Severe Weather event affecting numerous southern and eastern states;
- 3) the Central and Southeastern Tornado Outbreak and Severe Weather (150+ tornados) hit central and southeastern states; and
- 4) the Midwest / Southern Flooding and Tornado Outbreak (100+ tornados) hit the Midwest and southern states.

Once the results are in, these four events are expected to result in 2025 becoming the greatest single-year of weather-related damages to date. The LA Times estimates the total economic loss from the LA Wildfires have ballooned to more than \$250 Billion, making it one of the costliest natural disasters in U.S. history.

These natural disasters continue to leave an economic and traumatic imprint that lingers for many years, exacting their toll on families, communities, businesses, and local economies. The loss of loved ones, homes, neighborhoods, and the environment that nurtures them is a terrible blow to the citizens and their communities.

The question that needs to be addressed is *how this destruction and loss of life can be prevented or at least mitigated in the future*. Although not the solution to all scenarios, we believe that today's technology has some good answers that would minimize the damage to property, reduce the cost and time for repair/recovery of community assets and provide increased protection for the citizens themselves.

To accomplish these things, the destructive forces of water, wind, fire, lightning, and even seismic activity must be solved. The common denominator in these events is the ultimate failure or destruction of buildings and other support structures which are subject to those forces during these events. Our approach is to rebuild communities with a building system that can withstand these forces and thus reduce the damage and costs of recovery that has been experienced in the past. If the same building systems are used to replace the lost buildings, eventually a new event will likely result in the same kinds of losses. What is the remedy?

**The Edge Building System**™, offered by EDGE Enterprises, LLC, a Rancho Mirage-based developer, is a **manufacturer** of the world's most advanced Composite Construction System (CCS) for the building industry. Over the past 20+ years, prior technologies have paved the way to prove the success of CCS buildings through rigorous testing, certification by the International Code Council – Evaluation Services (ICC-ES) and by real-world applications. Although CCS has a proven track record of success in the building space, it has been limited in its reach to its full potential. Its time has now come for rapid and massive growth in every sector of the economy here in the US and around the world.

CCS utilizes advanced structural elements of composite materials which can be mass produced in a factory, delivered to the site, and easily assembled on-site to form a complete, enclosed building within a few weeks, not months. Once assembled, CCS buildings are virtually fire-proof, impervious to water and/or smoke damage. They offer complete resistance to corrosion caused by ocean spray & sea water, are mold-resistant and pest-proof (including termites). CCS building deliver industry-leading insulation results and an expected useful life of 100 years or more.

Completed structures are exceptionally strong and stable and can be engineered to withstand winds up to 200 mph as well as seismic events comparable to the San Francisco Bay Area Quake of 1989 (magnitude 6.9) and flooding – making these buildings among the safest structures made by man.

The basis of the structural material is the forming of a composite of an Expanded Polystyrene (EPS) foam core which is coated on both sides with a proprietary Fiber Reinforced Concrete (FRC) mix. When these composites are combined, the resulting mechanical bond creates a superior structural system allowing buildings to be erected almost entirely out of renewable materials used to form the walls, floors, and roof.

Once erected and sealed, the building becomes a single three-dimensional, box-like, structure that is completely encapsulated by the FRC skin. Even door and window openings are encapsulated to add more strength and rigidity to the structure. Wood and/or steel members are not needed for structural design but may be integrated for architectural value if desired. The CCS system eliminates the need for mechanical fasteners at building corners and roof connections – often the weakest points of the structure in conventional construction.

The resulting floors, walls, ceiling, and roof surfaces can be decorated with most conventional building materials to produce modern finishes and styles. The R-values of a CCS building's exterior shell are such that heating and cooling costs are dramatically reduced beyond that of conventional premium construction systems. Similarly, the shell delivers amazing sound reduction benefits as well. All elements of a CCS building can be modified and/or repaired using conventional tools with specific materials and techniques provided by [EDGE Enterprises, LLC™](#).

There is virtually zero construction waste throughout the manufacturing and erection processes and all EPS shavings from panel and column formation are bagged and reused in creating new panels and columns where no material is sent to a landfill.

# Real Solutions

At this point in history, we believe that the public demand is at an all-time high for better building methods - solutions that can address and mitigate those natural disasters and that can efficiently and economically restore those buildings damaged by them. With this CCS building system, American ingenuity and innovation have developed real solutions that can fulfill this demand.

Rather than reinvesting all the recovery funds, which will be spent to support disaster relief, toward the same conventional building systems that failed during these events, we suggest an investment into CCS by EDGE Enterprises to accelerate the recovery and to provide cost-effective and superior buildings that will help to prevent both the tragic loss of life and the loss of homes and businesses to which survivors cannot return.

Why rebuild damaged structures or build new ones using conventional building methods when homes and businesses can be rebuilt safer, faster, and more economically using a proven process that is environmentally responsible; is resource-efficient throughout a building's extended life-cycle; is more energy efficient; drastically reduces construction waste; and can resist whatever nature throws at it?

The CCS building method achieves all these goals and does so at a value-based cost that meets or exceeds current market pricing realities.

EDGE's organization includes an experienced executive and management team made up of highly trained, knowledgeable, and skilled personnel with a combined 120 years of experience specific to this system and to their respective areas of expertise, including materials procurement, factory oversight, personnel hiring, site building for residential and commercial structures, vendor selection, planning and budgeting, architecture and structural engineering, project management, and more.

To discuss what is required to utilize and implement EDGE's CCS building system to rebuild the recently devastated areas in LA County, the Texas High Country, and the Helene-devastated areas of Georgia, Tennessee, and North Carolina and the many other areas of our nation that have experienced the ravages of nature's destruction:

**Contact: Joseph Kraus, CEO, Edge Enterprises, LLC**

**505-780-0273; joseph@edgeus.ai**

# EDGE Enterprises

## The Company

- Formed on June 23, 2009, as a Limited Liability company in Santa Fe under New Mexico state laws, now located in Rancho Mirage, California and headed by Joseph Kraus.
- EDGE's exclusive focus has been and continues to be of the development and evolution of its innovative building technology that utilizes Expanded Polystyrene (EPS) as the core for all structural members, then coated with a proprietary membrane skin to form a mechanical bond to all structural members that results in a superior structural system.
- This building system technology allows buildings to be erected almost entirely out of renewable materials that resist hurricane strength winds, fire, earthquakes, hail and floods.
- This Construction Composite System (CCS) uses no screws, nails, or fasteners of any kind, wood or steel, and eliminates multiple labor steps in the construction process.

# How Does The CCS Building System Work?

## 4 Basic Steps

- Each structure is designed, analyzed, manufactured and constructed with **computer support** using a Finite Element Analysis (FEA) software program (Step 1).
- They are **CAD designed and CAM manufactured** for easy assembly (Step 2).
- The development of this building method has been researched, tested and proven for applications **utilizing any architectural design** for any environmental condition (Step 3).
- The combination of EPS/Skin and the simplicity of their assembly usher in a new era of **automated modular manufacturing** (Step 4).

# The Building System

Two Main Components:

Expanded Polystyrene (EPS)

Fiber Reinforced Concrete (FRC)

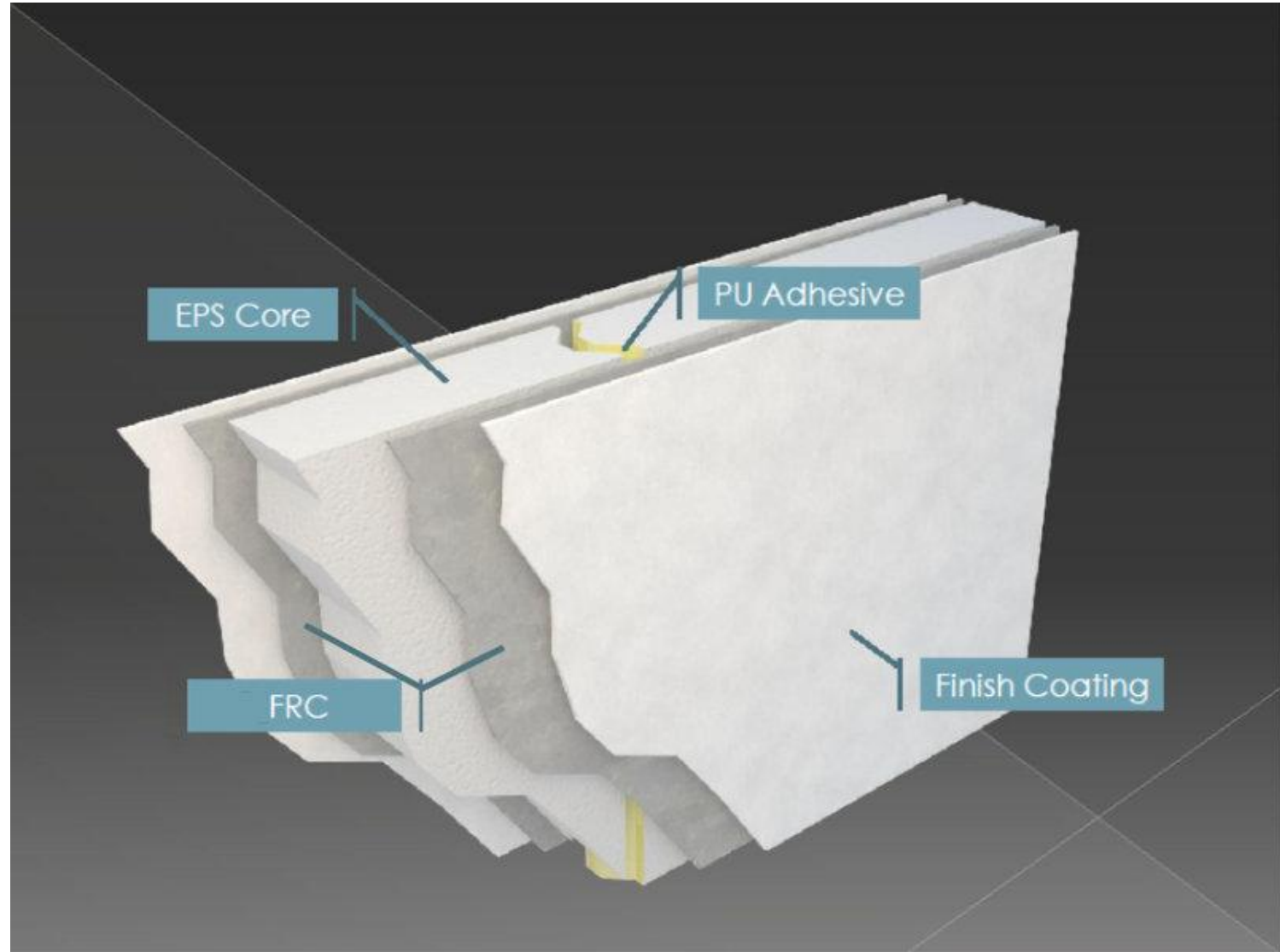

# Examples of Expanded Polystyrene (EPS) Structural Members for Floor, Walls, Roof

---

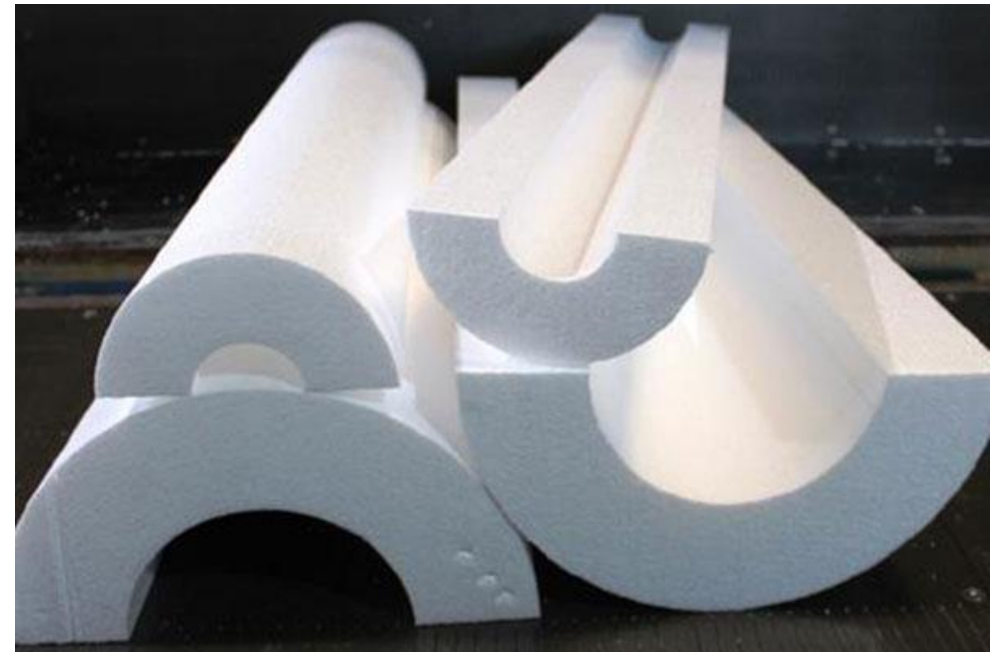
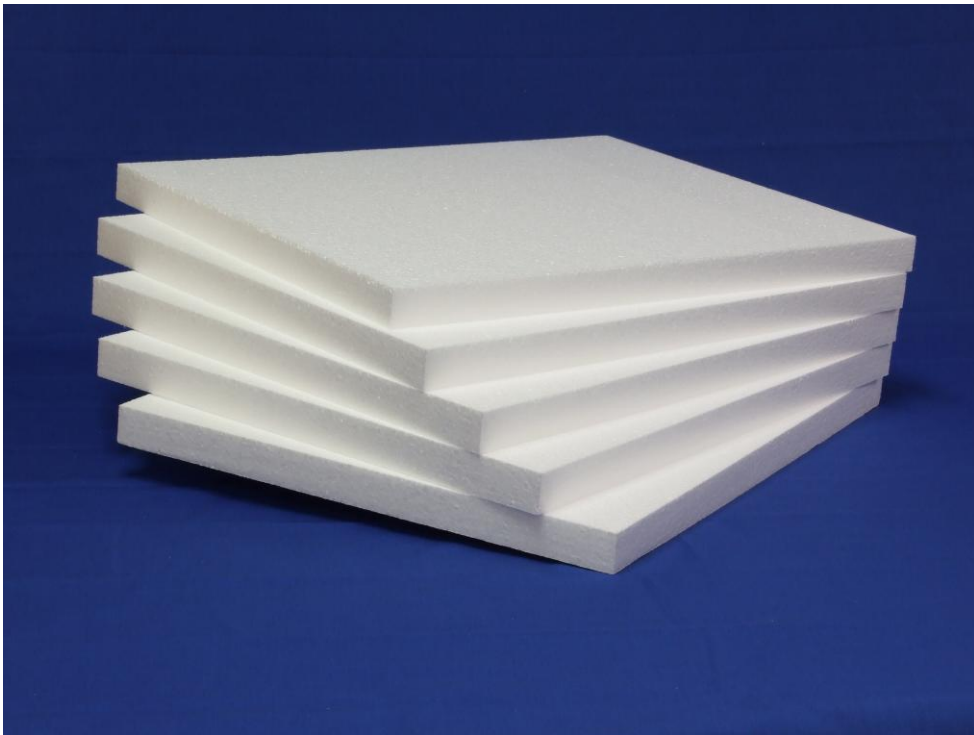

Curvilinear architectural capabilities

# Examples of Expanded Polystyrene (EPS) Structural Members for Floor, Walls, Roof

---

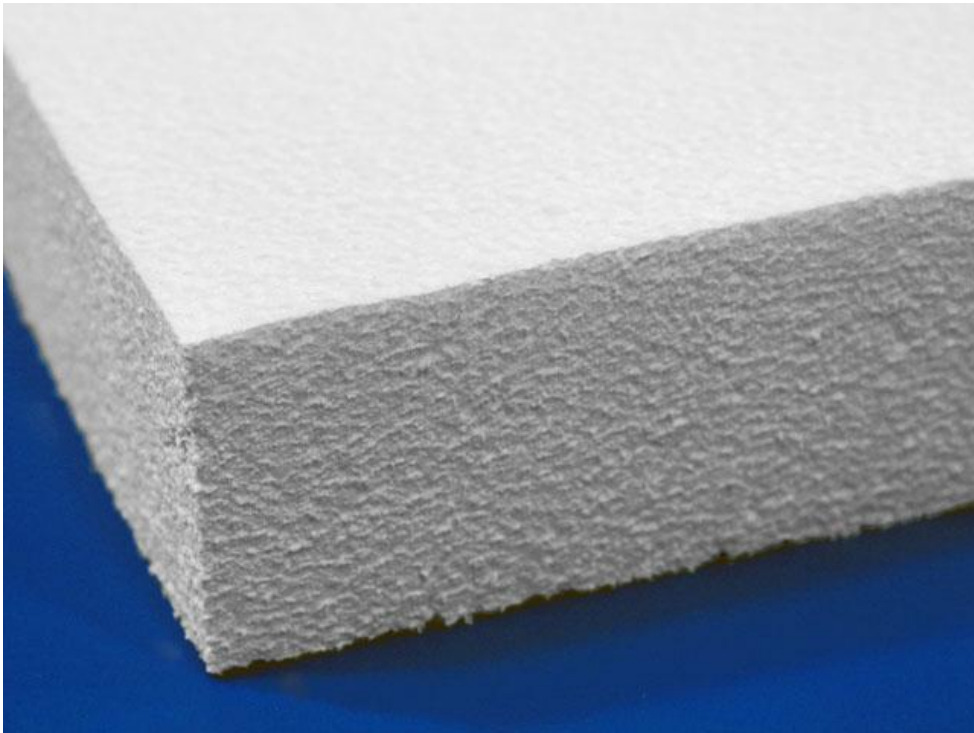

Sample billet

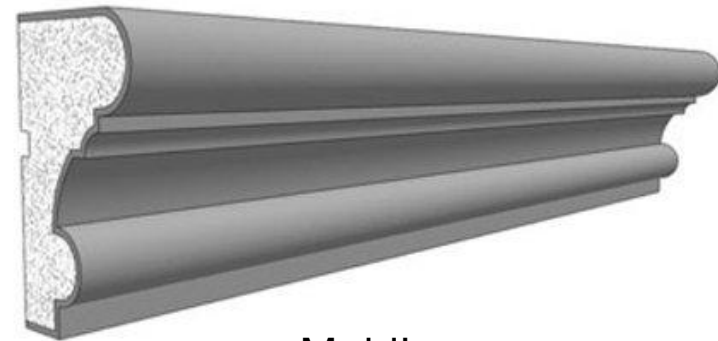

Molding

# Finished Manufactured EPS Block for Shaping Walls and Other Structural Members

Depending Upon the Nature of a Residential Building or Commercial Construction Project, these Billets can be programmed and manufactured in various sizes – lengths, widths, and depths.



Finite Element Analysis (FEA) performed on an architectural design (actual finished home in following slide) to identify critical load bearing areas To ensure accurate skin coating over the EPS structural members.

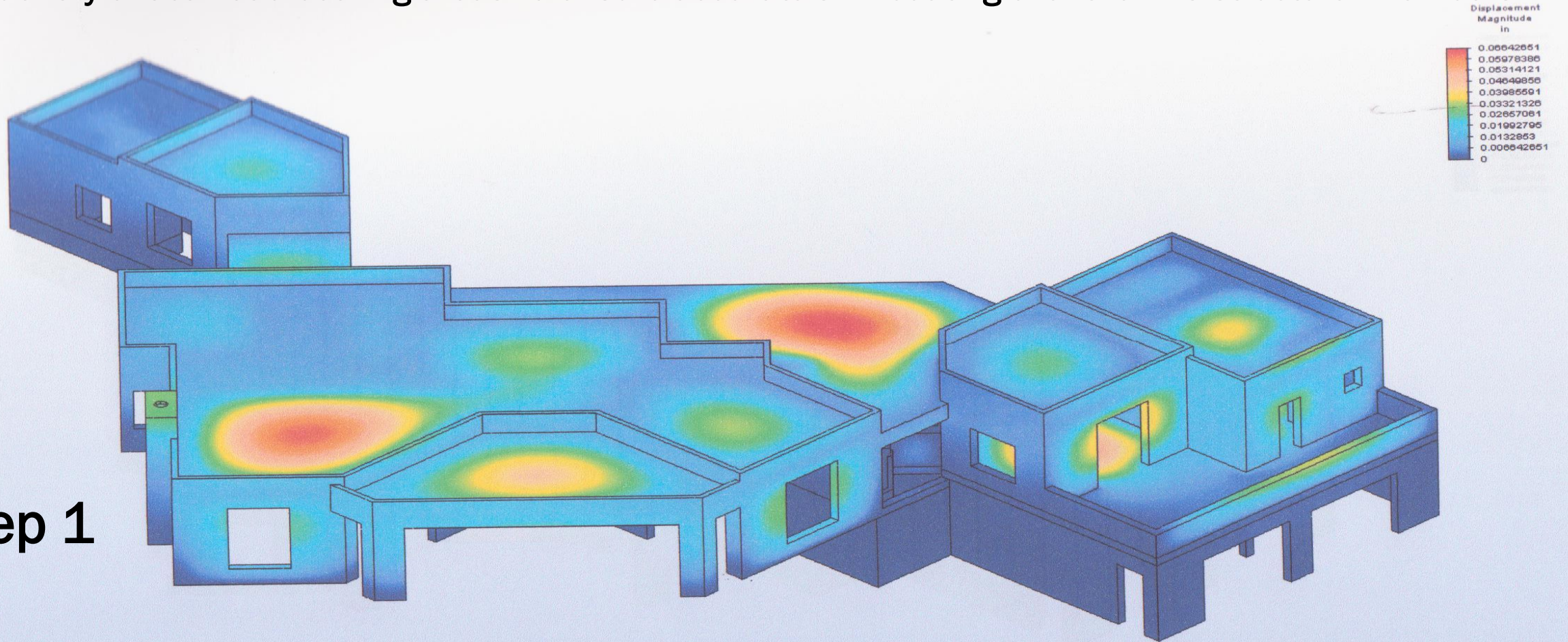

Step 1

Wagner House 90 mph Wind in (-X) Direction

Copyright © Strata International Group, Inc. 2009

Load Case: 1 of 1  
Maximum Value: 0.0664265 in  
Minimum Value: 0 in



Completed home that  
utilized the FEA process  
demonstrated in previous slide  
before construction.

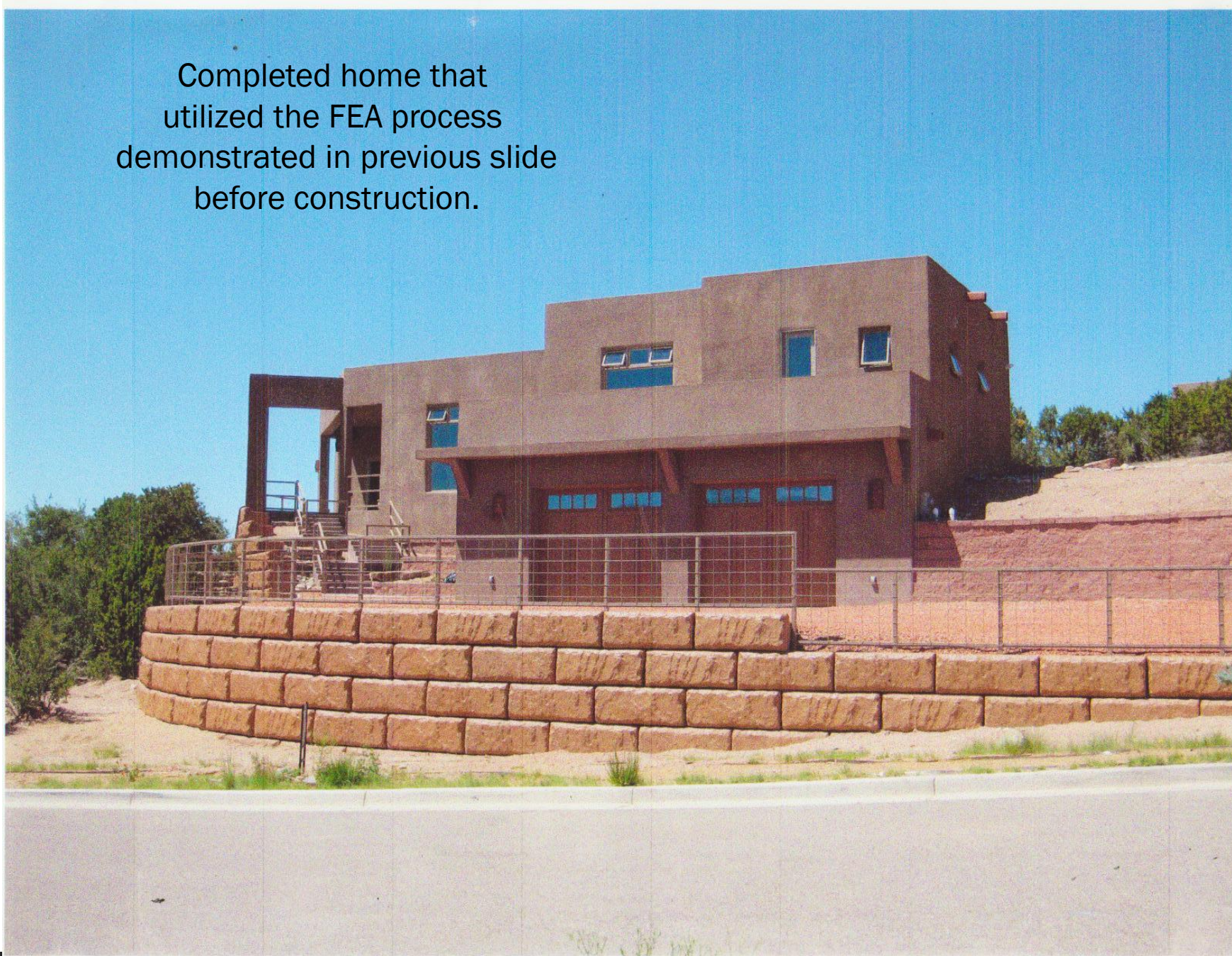

Another beautiful home built by EDGE Enterprises using its CCS building method located in Santa Fe, NM









# Step 2

## CAD designed and CAM manufactured

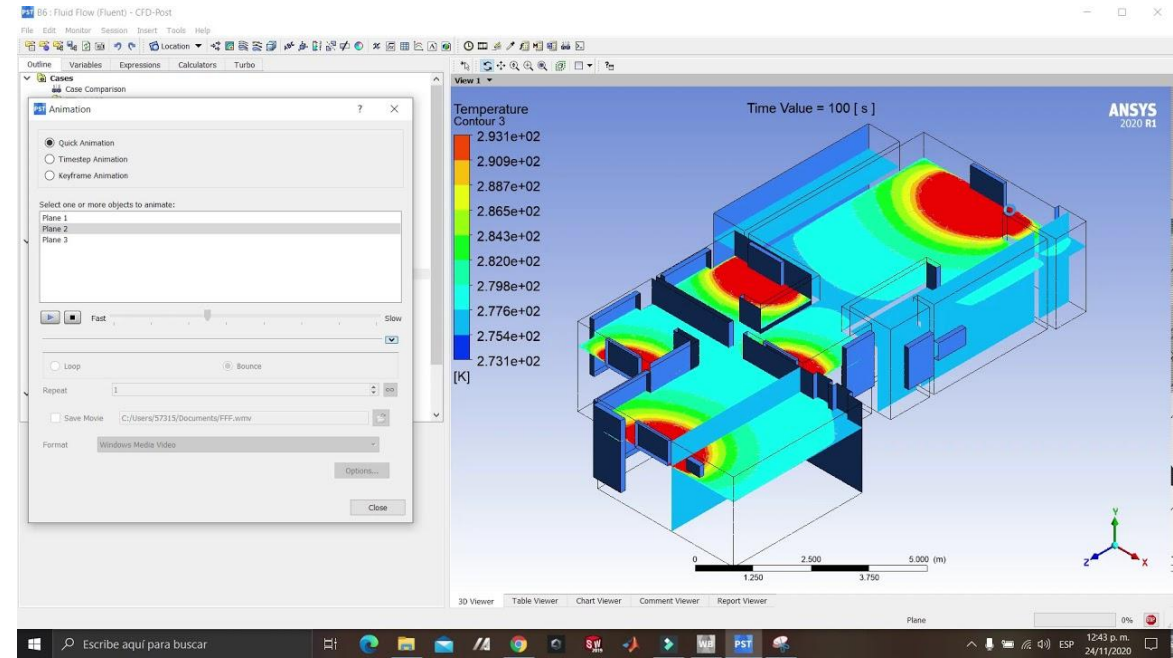
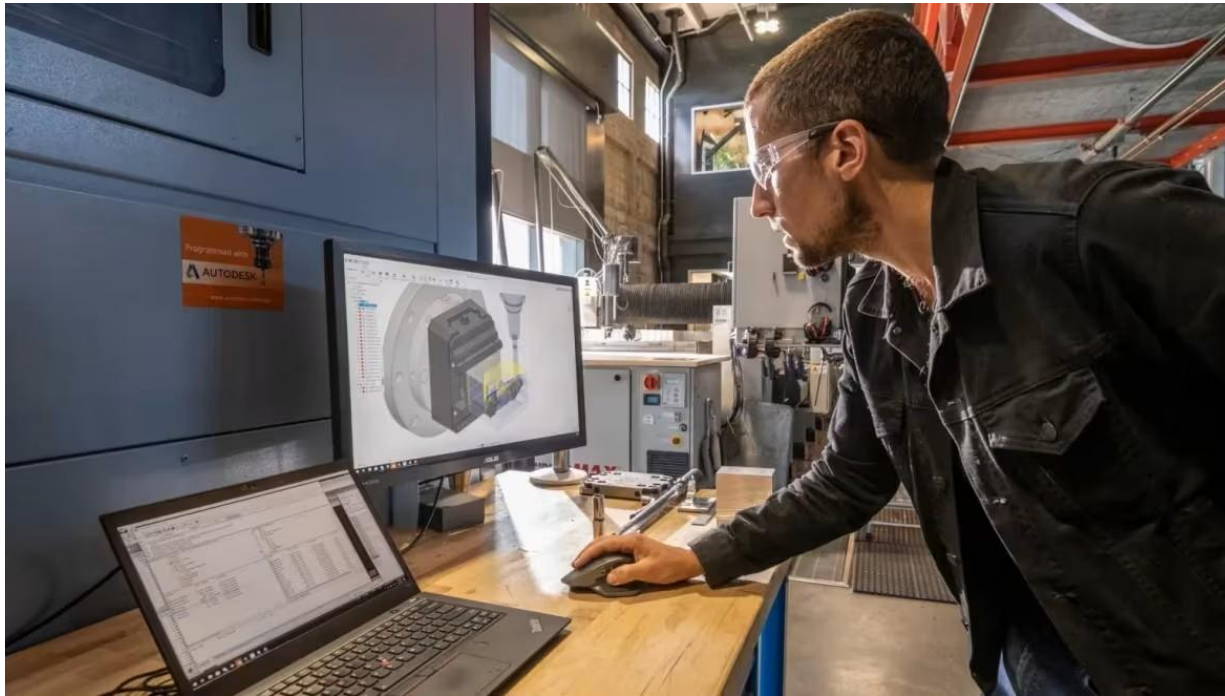

# Step 3      Imagine the Limitless

## Architectural Design Capabilities

---

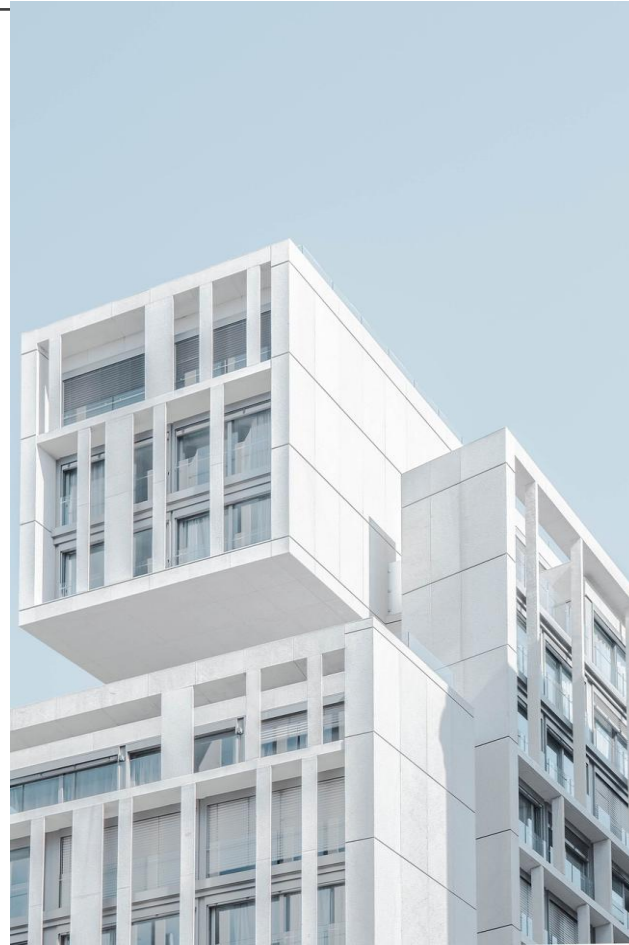

# Step 3 (cont'd) Imagine the Limitless Architectural Design Capabilities

---



# Step 4 Manufacturing

The manufacturing process keeps CO2 out of the atmosphere;

All fabrication and coating are EDGE quality-controlled;

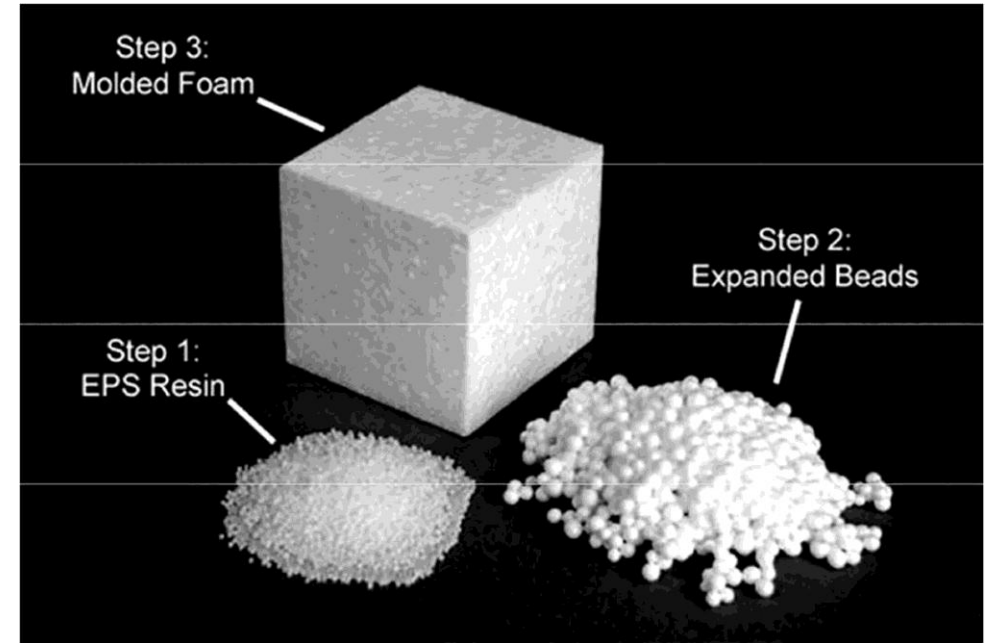

EPS blocks are made by taking small polystyrene beads and heating them to generate steam. The steam causes the beads to expand significantly and continuously and then molding them together in a mold under heat and pressure to form a solid block

# What Are the CCS System Attributes?

Proven Through Rigorous  
Testing and Verified by  
the International Code  
Council-Evaluation  
Service (ICC-ES)

- a. **HIGH WIND DAMAGE PROTECTION** – i. Tornados & Micro-bursts (Wind Shear) ii. Hurricane / Typhoon
- b. **EARTHQUAKE PROTECTION:** Building System will withstand seismic ground shifts with minimal or no damage or can be easily repaired in place.
- c. **FIRE PROTECTION:** Building System will suffer minimal damage from fires (including wildfires and conventional homes fire).
- d. **HUMIDITY DAMAGE PROTECTION:** Impervious to Flood Waters (Internal and External) ii. Eliminates Fear of Mold and Mildew
- e. **VECTOR CONTROL:** No Insect or Rodent intrusion ii. Termite-proof materials
- f. **CLIMATE CONTROL:** Most energy efficient building system available reduces HVAC loads and electric/gas bills. ii. Minimal heat transmission through exterior walls
- g. **SOUND CONTROL:** Exceptional noise reduction is achieved by the composite system preventing most sounds from travelling through the exteriors walls. ii. Additional internal sound attenuation can be achieved with appropriate finishes on walls, ceiling, and floors. *Perfect for hotels, motels and hospitals.*
- h. **ENERGY CONSERVATION:** The national average for R-Value Codes is 19 for walls and 36 for ceilings/roofs. Structures built with CCS display R-Values of 40 and 70 respectively where energy savings for heating and cooling can be upwards of 90%. Additionally, structures built with CCS are air-tight. Consequently, air-exchange systems can be installed to bring in fresh air from the outside.

Imagine a home with radiant heat in its floor and not having to turn on the heat in cold weather because the heat generated from the refrigerator, washing machine, dryer, computers, lights, stove, oven, television and other off-heat-producing devices are the cause.

# What Are the CCS System Benefits? For Builders and the Trades

## CCS SYSTEM IMPROVES SCHEDULING CONTROL

1. The EDGE system is pre-manufactured to custom specifications and shipped to the site for erection while foundation & utility rough-ins are being completed;
2. Erection of a complete, dried-in, 1-story building shell should take 1-3 work weeks for up to 3000 SF of living space;
3. MP&E trades can then be scheduled to finish rough-ins;
4. Surface repairs and patches require 1 week after rough-ins.
5. Windows & Doors added for secured premises.
6. Flooring, walls and ceiling treatments installed.
7. Cabinetry, Fixtures, Equipment, etc. installed.
8. Trim Work and Appliances Installed  
Final Inspections and Punch List Work.

# What Are the CCS System Benefits? For Builders and the Trades (cont'd)

## The The Builder:

### 1. Saves Money and Time:

a. 1-3 weeks complete dry-in shell constructed on existing foundation;

b. Wholesale pricing: Save 2%-4% of conventional shell market cost;

c. Additional Incentive pricing for new market introductions – varies up to 5% of standard pricing – (may include volume and pre-paid sales);

d. Faster Delivery To Customer (CLOSINGS) reduces costs;

e. Shell pricing advantage yields Extra Profits;

f. Upselling Building System Advantages increases selling prices (with no extra cost to the builder) resulting in More Profits;

g. Customer satisfaction increases demand for the product and even More Profits.

h. No construction waste.

# What Are the CCS System Benefits? For Consumers

## The Consumer

1. State-of-the Art Building System with unmatched benefits built-in (see PROTECTION and CONTROL advantages back 2 slides).
2. Increased comfort in home due to reduced outside noise, energy bills, and pests. R-value approximates 5/inch.
3. Insurance premium reductions resulting from underwriting of this special building system which is protected from costly natural and man-made disasters.
4. A highly durable building system that will not deteriorate. Expected building lifespan is in excess of 100 years with minor period maintenance and/or repairs.
5. Impact damage can be easily and rapidly repaired.
6. Maintains higher resale property value for multiple decades.
7. Pride of Ownership – The “Platinum” of New Homes.

# What are the CCS System Benefits?

## For Insurance Companies

### For Insurers

Reinsurance costs are lowered significantly because protection against catastrophic losses are increased due to the attributes of the CCS System's capability to resist damage caused by fire, gale force winds, and floods;

Lower volume and value of insurance claims;

Inflation and materials shortages will not factor in the financial strain and profitability of these companies because the associated rebuilding costs are themselves a non-factor;

Raising premiums to compensate for the increased risks and costs to the extent that homeowners cannot afford them may be unnecessary;

The combined effect of escalating wildfire risks, financial pressures on insurance companies, and regulatory challenges does not have to lead to a retraction of insurance coverage in fire-prone regions, leaving homeowners with fewer choices, higher costs, and the risk of being underinsured or uninsured.

# Edge's Business Model

Supported by  
Experienced  
Leadership and  
Profit-Driven

Contractual relationships are established with developers, project owners, architects, builders, materials companies, and other interested parties.

Manufacturing plants and erection crews will be expanded regionally to meet demand for The EDGE CCS.

Factory production involves two (2) overlapping shifts at start-up..

Each manufacturing plant will be capable of producing one 2500 SF home per day. With a lead time of 3 months, additional equipment and personnel can be added to double the plant output.

The Senior Management team at EDGE Enterprises LLC possesses more than 120 years of combined experience in the construction industry and involvement in the development, testing & execution of the CCS technology for real world applications and execution.

# Edge's Competition

SIPS

ICF

Conventional  
Construction

**SIPS** (Structural Insulated Panel System) rely on wood truss systems and use plywood and gypsum drywall as surface materials.

**ICF** (Insulated Concrete Forms) uses foam type blocks or wall sections as forms into which concrete is poured over reinforcing rebar.

Both systems offer panelized wall solutions and must rely on thick concrete foundations, gypsum wallboard and conventional roof systems, require larger on-site crews and longer building cycles.

EDGE's CCS is a unique SIP that requires NONE of the materials or labor steps involved in traditional SIPS or ICF. As a CCS panel is considered to be a SIP, vapor barriers, steel, gypsum wallboard, screws and nails are not required for installation.

CCS replaces most **conventional construction** methods and labor practices. (See Next Slide)

# EDGE Enterprises

## Comparison to Conventional Construction

1. *Edge Enterprises, LLC is a manufacturing company that provides a factory-controlled environment offering the highest level of quality control in the manufacture of all structural members a building design requires;*
2. *75% of labor is taken out of the construction process;*
3. *The FRC mix design is touted for its flexibility. It moves and bends with the EPS without cracking, even across large expanses giving a CCS structure the capability of withstanding hurricane force winds. There is less movement, less expansion, and less contraction.*
4. *A completed structure built with the CCS building method demonstrates that its combined tensile strength is greater than any tensile stresses found in its environment.*
5. *There is little materials waste on a CCS job site; any that exist are recyclable.*

# Marketing's Role Promotion and Verticals

CCS is promoted to architects who choose the CCS system for their client's projects due to its design flexibility and sustainable attributes.

Several emerging market trends help CCS to capture a solid market position:

- Increasing age/decay of existing buildings
- Increasing need for natural disaster repair/preparedness
- Increasing cost & shortage of raw materials
- Growing global need for affordable housing
- Military housing applications

CCS can be applied to residential, commercial, municipal, military, affordable/low-income housing, custom homes, high-end tract developments, environmentally controlled warehousing, and dozens of ancillary products and hardscapes..

# EDGE Enterprises Completed Home Shown in Phases

---



# Photographs Depicting On-Site Delivery of Wall and Roof Panels

---



# EDGE Enterprises Completed Home Shown in Phases cont'd

---



# EDGE Enterprises Completed Home

---



# Development Opportunity in Motion

Bel Air Greens

35 Acres

71 Residential Lots

Edge Enterprises, LLC has positioned itself for a substantial land purchase by agreeing to a Letter of Intent upon which Edge will construct 71 homes with an average home size of 3000 sq ft using its proprietary technology.

Projected home prices: \$1.8M – \$2.2M to include upscale appliances and realizing a profit that doubles Edge's construction costs.

Edge's position here provides a reasonable incentive for an investor to recognize the foundation for Return on Investment negotiations requirements.

# Job Creation and Job Growth

The factory environment will transition from an initial manual operation to semi-automated to fully automated to robotics efficiently over a brief time period.

Job Categories Initial Factory: 79 Newly Created Jobs  
(Duplicated with Each Factory Expansion)

Computer systems programmer/architect

Fabrication

Construction Crew

Finish Crew

Engineering

Detailing

Process – contract, soil tests, architect design, engineering support, blueprints, 2D, 3D, FEA (Finite Element Analysis)

While EDGE utilizes, initially, a semi-automated process in its manufacturing facilities, this process will yield quickly to full automation, then to an automated-robotics process to meet ever increasing demand!

# A Word About the “One Big Beautiful Bill”

that became law on July 4, 2025

Invest in the Building Technology Offered  
by EDGE Enterprises, LLC.

**It's Backed by American Ingenuity and  
Innovation,**

Note: reference IRS form 4562, Section  
179 Deduction.

Potential investors are encouraged to  
contact their tax advisor to determine  
which assets qualify for the deduction  
under 179 (aka-Qualified Business  
Income or QBI).

The One Big Beautiful Bill widely opens the door for firms to invest in and benefit from 100% expensing for new construction equipment and technologies, construction of new high-tech manufacturing that focuses on energy-efficient residential and commercial buildings, research & development infrastructure, and process innovation that includes robotics.

EDGE is ready to build and given the provisions of this OBBB along with its building method that utilizes a technology that replaces structures that can withstand Mother Nature's devastating effects demonstrated in the recent LA County fires, hurricane Helene in North Carolina, Tennessee and Georgia, and the floods in the Texas high country there is no better time to invest in EDGE Enterprises to accomplish this together than now.

Future planning includes a robotics-driven manufacturing facility that will increase high-value paying jobs within multiple regionally-located manufacturing facilities and distribution centers.

# A Word About the “One Big Beautiful Bill”

that became law on July 4, 2025  
continued...

Invest in the Building Technology Offered  
by EDGE Enterprises, LLC.

**It's Backed by American Ingenuity and  
Innovation,**

Note: reference IRS form 4562, Section  
179 Deduction.

Potential investors are encouraged to  
contact their tax advisor to determine  
which assets qualify for the deduction  
under 179 (aka-Qualified Business  
Income or QBI).

1. The sector in which **Edge Enterprises** is involved offers a high rate of return on investment;
2. **Edge's** imminent automation is part of the next industrial revolution;
3. **Edge's** strategic technology and innovation makes it a highly productive company with unparalleled growth potential for the future;
4. **Edge's** advanced automation planning and productivity will result in explosive growth;
5. Invest in **Edge Enterprises** - this American company is a productive asset with its innovative proven technology.



Gaza



Ukraine

## The Board of Peace

Rebuilding the devastated worn-torn areas of Gaza and Ukraine ought to include the CCS building system – its capabilities and its benefits - as it comes along side conventional building methods.

Mr. Kraus' training in architecture in the School of Architecture at Kansas State University came late in his professional career when he initially devoted his professional endeavors to the garment industry, owning a manufacturing company based in Dallas and a Show Room based in Los Angeles specializing in Sportswear. Not only did he work out of his Dallas office but strategically maintained an apartment in Manhattan in the middle of the Garment District.

Upon becoming aware of an alternative building method that could utilize his skills in architectural design, Mr. Kraus, who at this time was owner and CEO of El Milagro Construction based in Santa Fe, New Mexico, later to be renamed EDGE Enterprises, LLC, became one of the first in the US to be licensed with this unique, problem-solving non-conventional building method and the first to prove its viability by constructing multiple projects using it, primarily in New Mexico and California. His experience in this regard has attracted to him and to EDGE Enterprises a vast and diverse contingent of experts in all aspects of this construction method totaling a combined 120 years of R&D experience.

The preceding is to what he devotes his life. His reputation over 26 years in the building/construction industry is recognized most by his ability and knowledge to take architectural renderings into the permitting process and experience a one-week or less approval eliminating unnecessary delays. He has municipal and state references to prove it.

# Joseph Kraus

CEO, Edge Enterprises, LLC

### **Mike Driver, Senior Advisor for Operations**

Construction Materials, Quality Control, Testing, 47 years experience in structural and architectural concrete, masonry, GFRC, GFRP, GFRG, Prestress, Post Tension. Member ACI. Professional Forester Senior Advisor at Cambridge International Advisory Group.

### **Dennis Cain, Director of Engineering**

Civil Engineer (PE), Surveyor, Entrepreneur, Contractor, Subdivision Developer, Chief Civil Engineer for 1982 Worlds Fair (Knoxville, TN), 42 years in Real Estate Development including 3 Master planned communities (Residential, Commercial Industrial) as Director/VP of Development. Project Manager, Construction Manager, Designer, Engineer & Consultant.

### **Julia Johnson, CFO & In-House Legal Counsel**

J.D. Duke Law, Global Finance Degree Oxford Said, Senior Director Cambridge International Advisory Group, Member of New York Bar, D.C. Bar, Georgia Bar, California Bar.

### **Floyd Gray, Chief of Staff & Operations**

General Motors Industrial Job Sites Mechanical Engineer, also experience in Case Load Management, Staff Scheduling and Billing.

### **Mark Allison, Field Superintendent**

36 years experience as CEO, Operations Manager, VP, Project Manager, Construction & Development in custom luxury homes, light industrial and commercial.

### **Carl N. Tichenor, Corporate Communications**

Former Publisher, American Builder Magazine, American Contractor Magazine, AUA News Journal. A decade of experience in Investor Relations, Corporate Communication International Vendor Relations.

# Additional Leadership

# CONTACT

Joseph Kraus

CEO

Edge Enterprises, LLC

505-780-0273

[joseph@edgeus.ai](mailto:joseph@edgeus.ai)

Details pertaining to identified phases of requested investment funding, operating capital, and annual profit projections is available in a separate document.